

A-MF100 Installation Instructions

1. Center the steering wheel with the front wheels pointing straight ahead.
2. Remove right and left drag links from the spindle steering arms to the steering gearbox pitman arms. The drag links will not be reused.
3. Install power steering pump. (1)
(Note right & left are determined while sitting in the operator's seat.)
4. On the left side of the tractor, install cylinder bracket (2) by welding to the existing radius rod. The center of the hole on this bracket must be 32-1/2 inches from the center of the hole on the existing steering arm.
5. Install power steering cylinder (3) between the bracket and existing steering arm.
6. Install pressure hose (4) from the pump to the cylinder.
7. Install return hose (5) from the cylinder to the pump.
8. Install new drag link (6) from existing pitman arm to the control valve on the cylinder.
* Do not force the drag link onto the control valve. You may need to center the cylinder to install. *
9. Tie rod arms (7) provided with the kit must be welded to the bottom of each spindle. The distance from the center of the hub to the center of the tie rod hole must be 4-3/4 inches.
10. Assemble and install three-piece tie rod (8) and adjust toe-in.
11. Fill reservoir with power steering fluid.
12. Start engine and turn the steering wheel back and forth several times to purge the system of air.
13. Recheck fluid level, and add if necessary.
14. Adjust pressure valve on cylinder if required.
15. Recheck tightness of mounting hardware and hoses after one week.

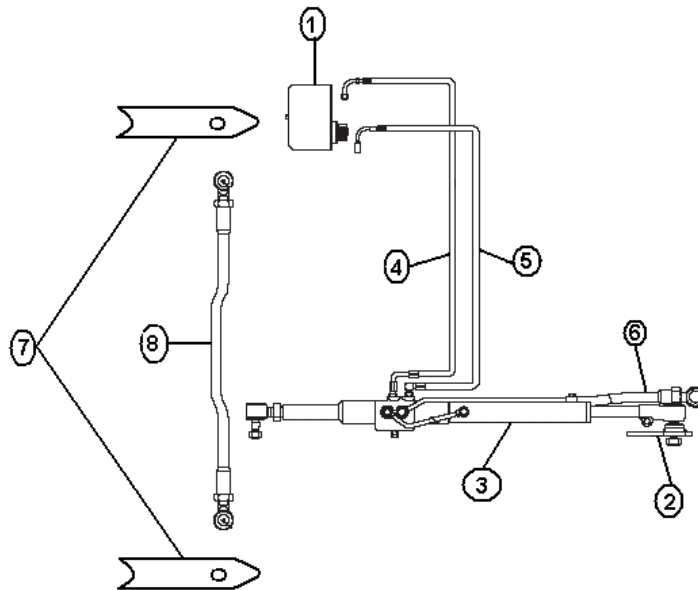

OMMF100